

GT2A48A+GT2A80+GT2A80---DRD Can layout

Process flow

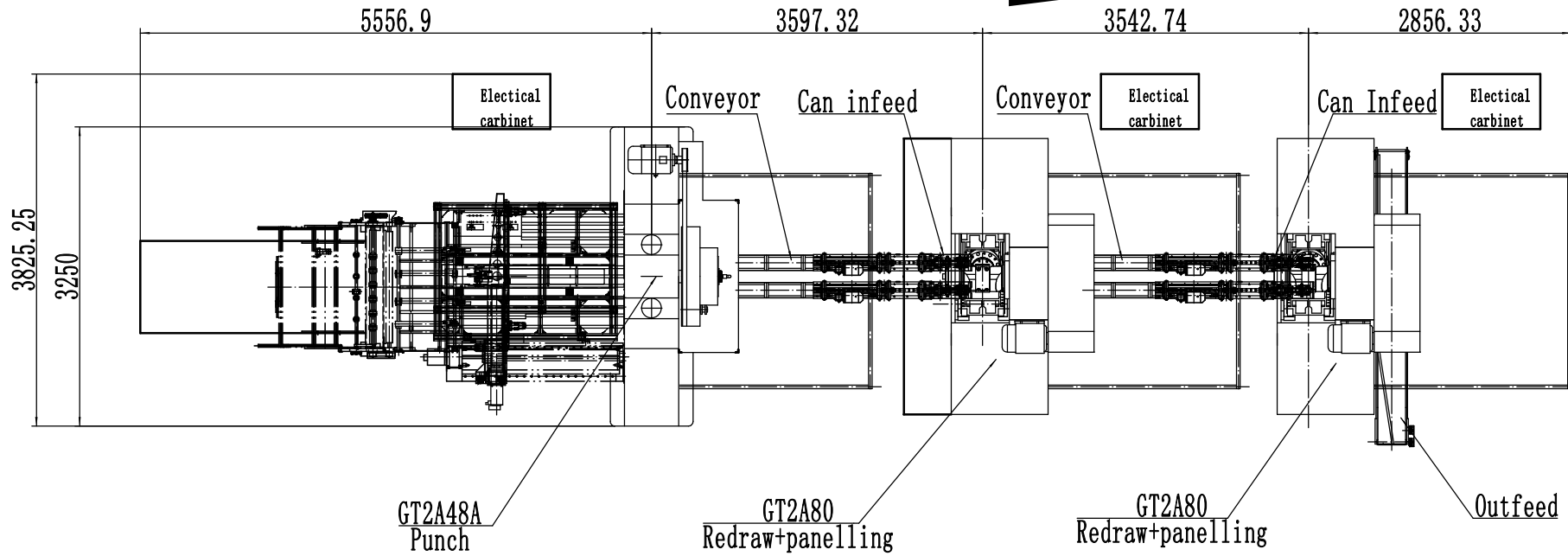

GT2A48A
Punch

1. Nominal pressure: 80T
2. Press strock: 120mm
3. Strokes max: 120SPM
4. Tooling max : 2
5. Material size max : 1040X1040mm
6. Die shut height max: 400mm

GT2A80
Redraw+panelling

1. Norminal: 800KN
2. Press strock: 170mm
3. Strokes max: 120SPM
4. Tooling max: 2
5. Die shut height max: 400mm

GT2A80
Redraw+panelling

1. Norminal: 800KN
2. Press strock: 170mm
3. Strokes max: 120SPM
4. Tooling max: 2
5. Die shut height max: 400mm

Outfeed

Capacity max: 200CPM

										GT2A48A型CNC全自动压力机			
设计	徐	崇	华	化						册号	张数	张数	比例
审核										4		1:25	
工艺										共张		第 页	

